

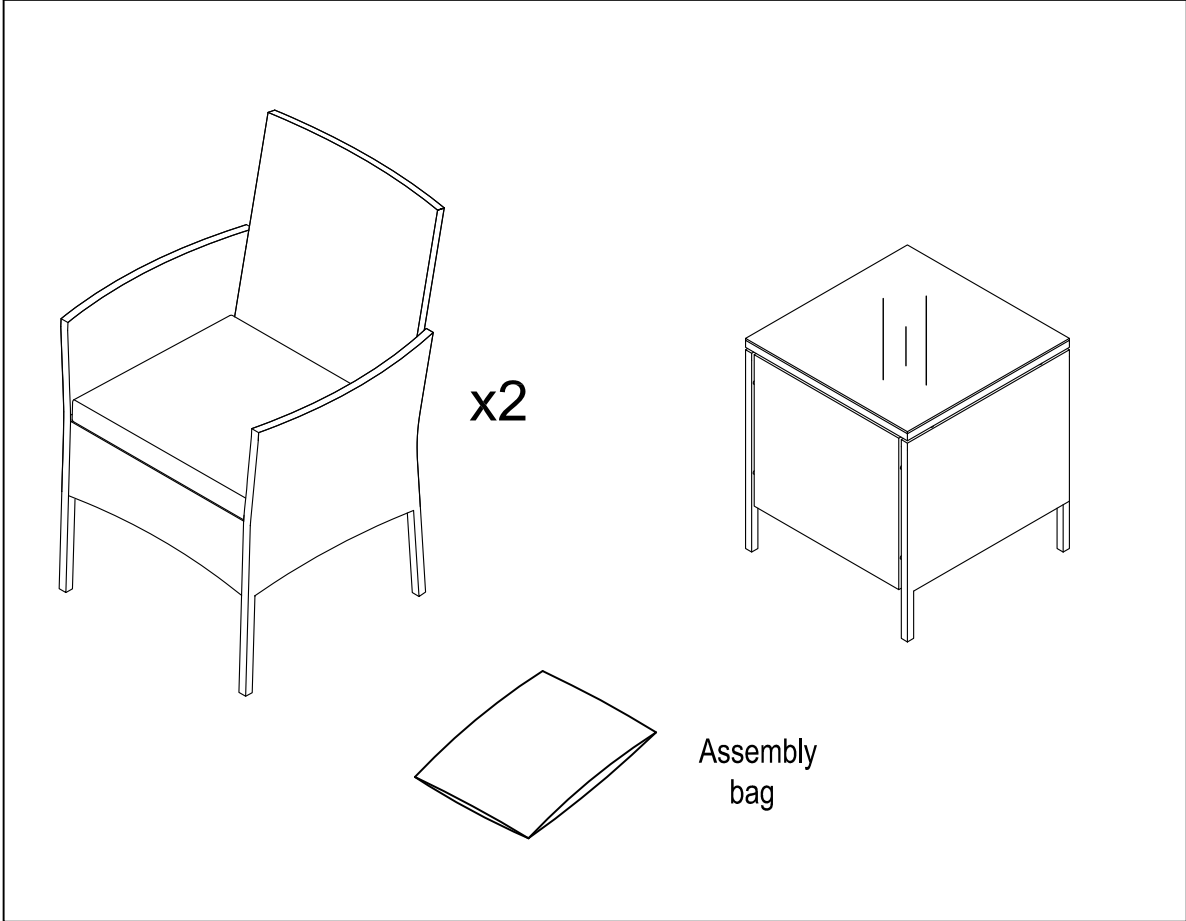

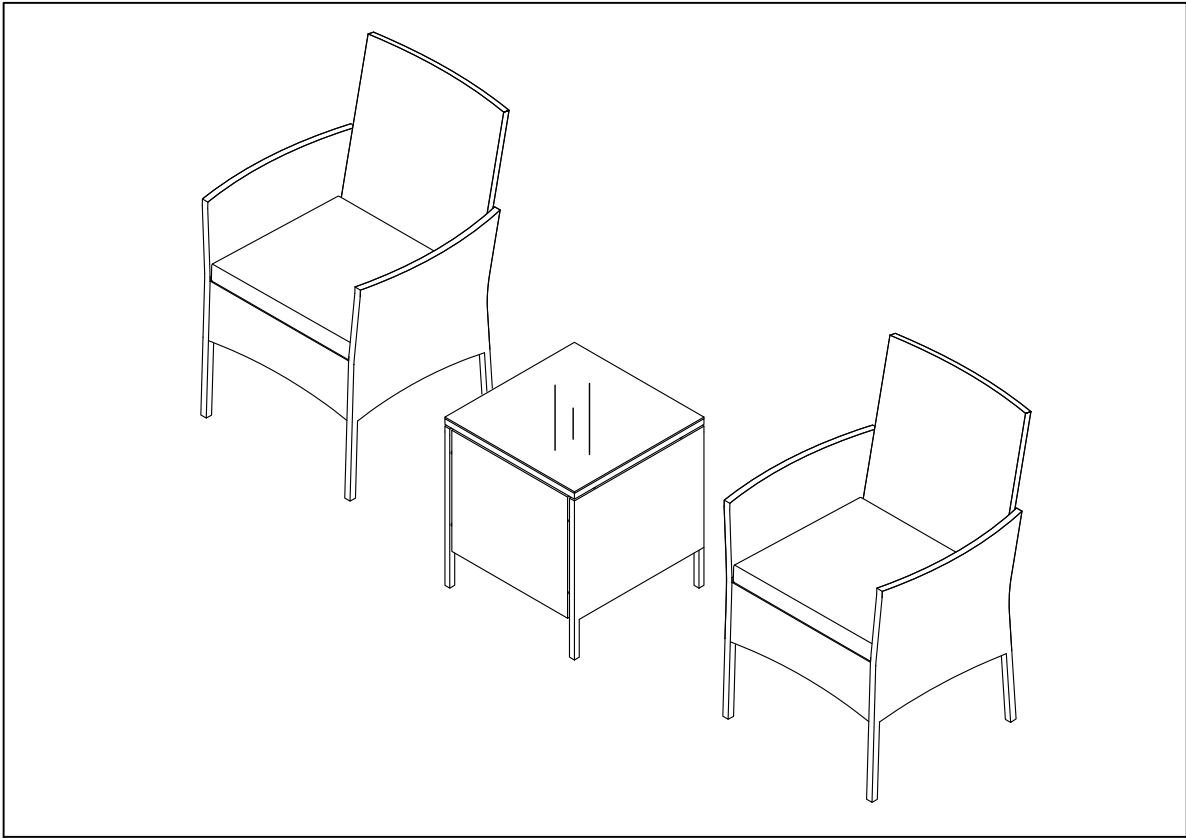

# 3-PIECE WICKER BISTRO SET

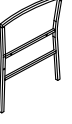
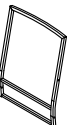
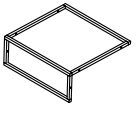

## Chairs (Do this two times)

Item no.	Reference Image	Description	Qty.
A		Left Arm Rest	1
B		Right Arm Rest	1
C		Seat Back	1
D		Seat Base	1
E		M6 x 35 Socket Head Cap Screw	10
F		Flat Washer	10
G		4-mm Allen Key	1

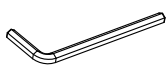
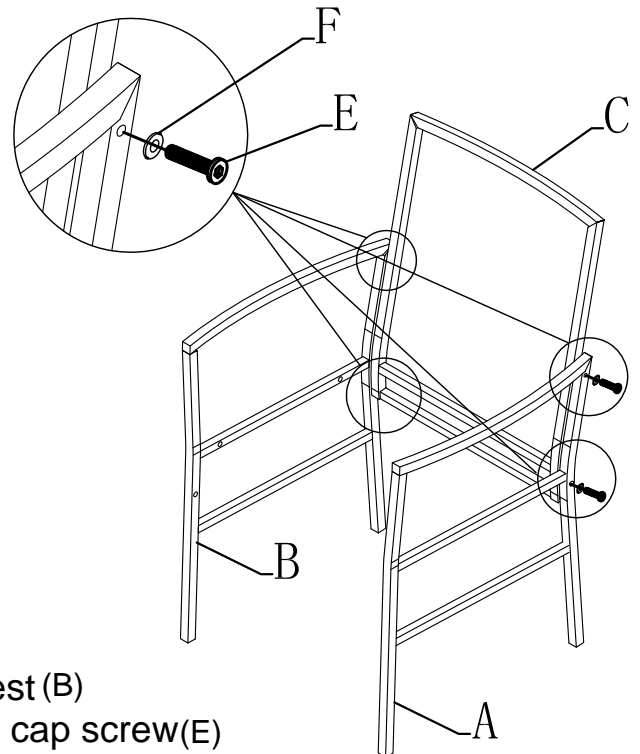
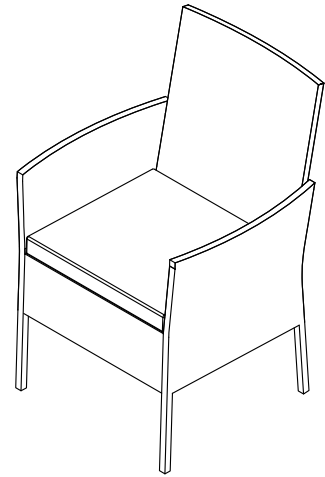

**1**

Attach the left arm rest(A) and right arm rest (B) to seat back (C) using M6\*35 socket head cap screw(E) with a flat washer(F) as shown. Do this in four places.

## Chairs (Do this two times)

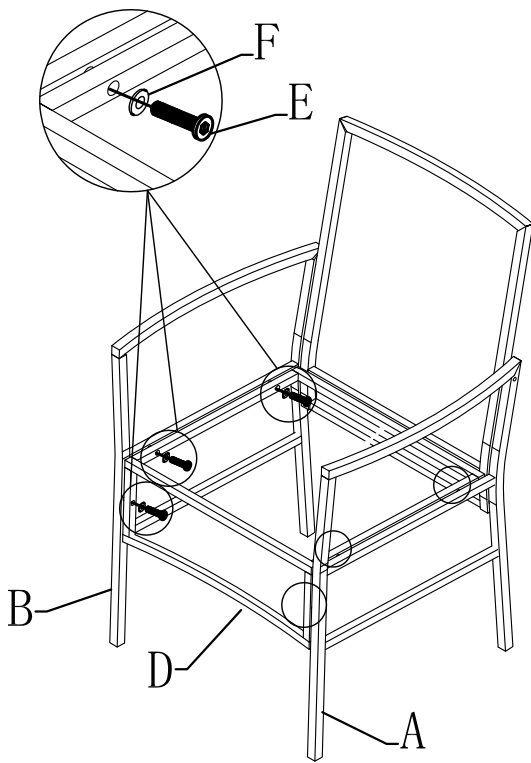





**2**

Secure the seat base (D) to the arm rests (A & B) using M6 x 35 screws (E) with a washer (F).

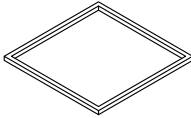
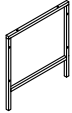
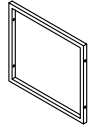
Do this in seven places.

## Coffee table

Item no.	Reference Image	Description	Qty.
H		Table Top	1
I		Table Leg	2
J		Leg Brace	2
K		Glass Top	1
E		M6x35 Socket Head Cap Screw	12
F		Flat Washer	12
G		Allen Key	1

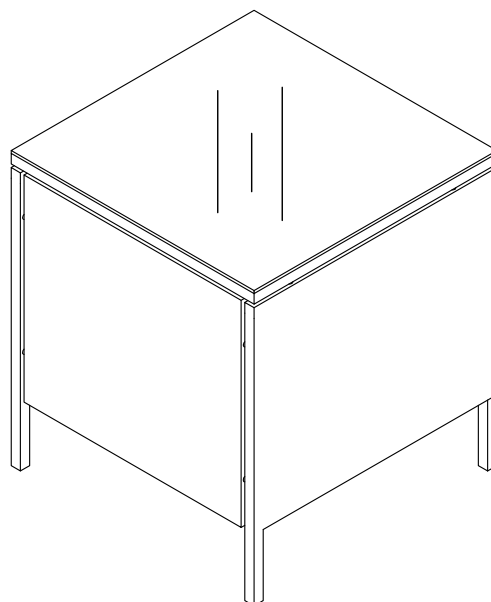

①

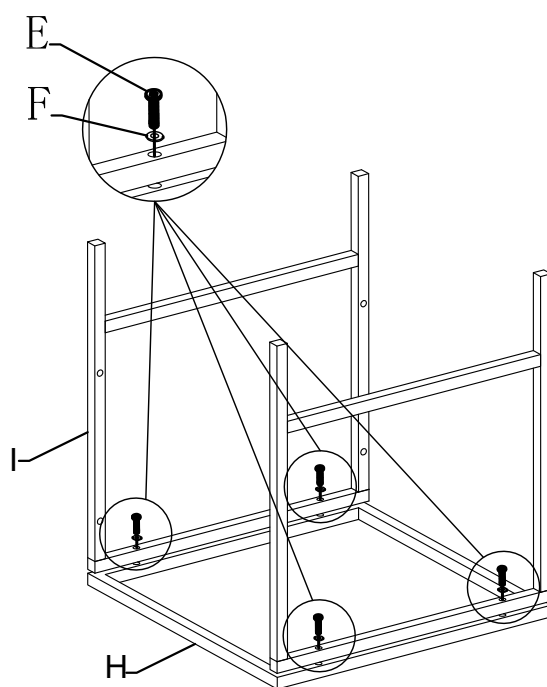

1

Prepare (H) Table Top and attach two (I) Table Legs with four (E) M6x35 Screws and (F) Flat Washers at each of the four locations. Use (G) Allen Key. DO NOT YET TIGHTEN

## Coffee table

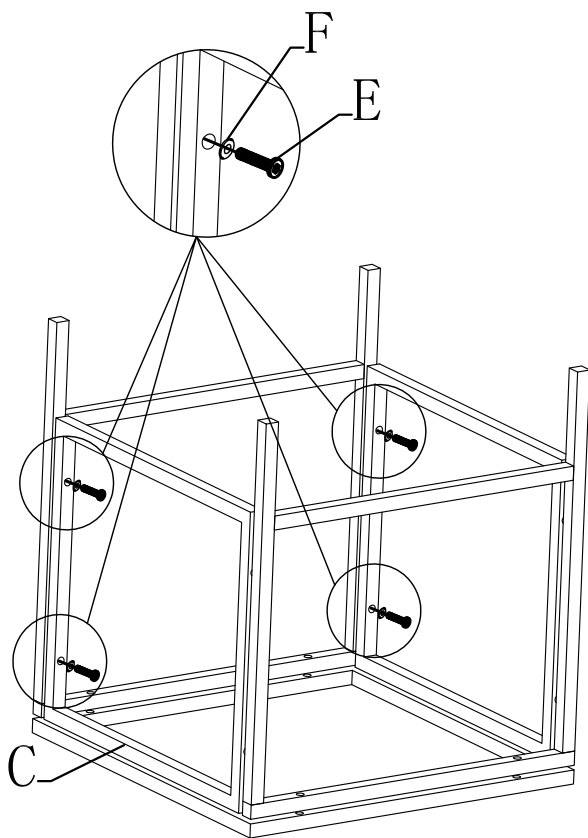

**2**

Attach two (J) Leg Brace to two (I) Table Legs with eight (E) M6x35 Screws and (F) Flat Washers. Use (G) Allen Key. DO NOT YET TIGHTEN

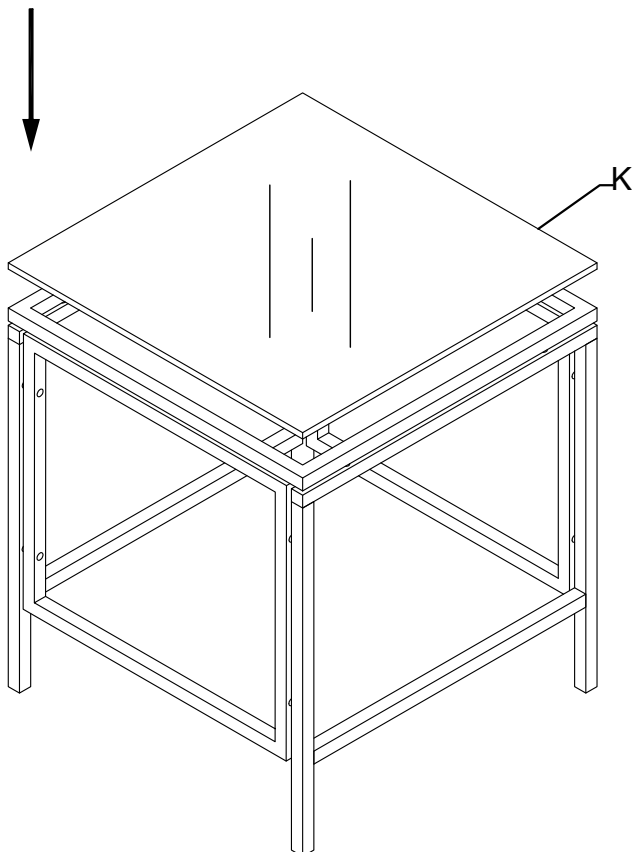

**3**

Stand up the assembly and place (K) Glass Top on (A) Table Top Well done!